

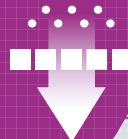

**FILTRATION
& DRYING**



**HIGH
QUALITY
COMPONENTS**

**CRYSTALLIZATION
FILTRATION**

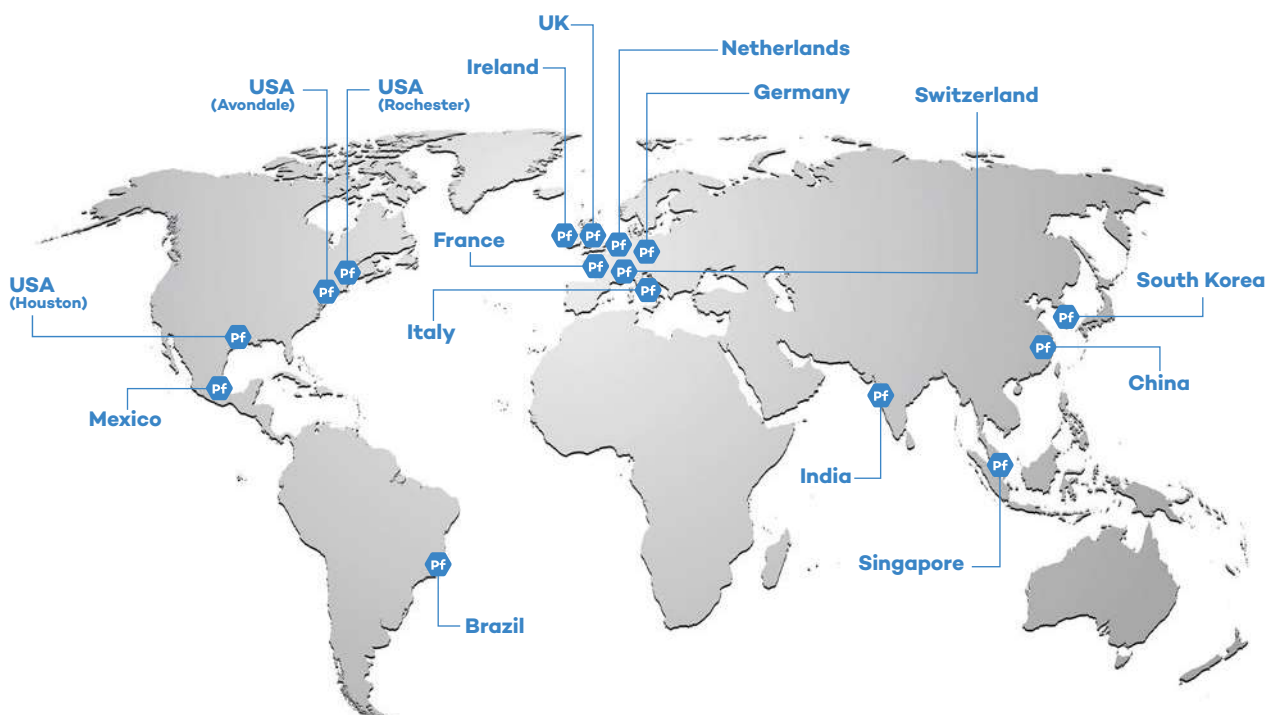

Pfaudler International

One single source responsibility with access to all Pfaudler Technologies, Systems, Services worldwide



Pfaudler is a global Group offering a wide range of **corrosion-resistant technologies, systems** and **related services** for the **chemical, pharmaceutical** and **food industries**.

Edlon, Interseal, Montz, Mavag, Normag and **Pfaudler** are our Branded Product Lines.

These product lines are specialized and perfectly integrated to **meet the most complex Client needs**. We are in the position to offer a **complete turn-key package** for each of the critical aspects of chemical and pharmaceutical processing.

Technologies and process systems of our Group are installed in more than 100 countries and across six continents. Unique expertise and skills, **manufacturing capability**, targeted investments in strategic markets, innovation and competitiveness allow the Pfaudler group to be a landmark in the industry.

Around the world our Customers rely on the quality and performance of our supply to obtain efficient, reliable, profitable and safe chemical process systems.

Our network organization is designed to:

- strengthen our local presence alongside Customers and markets;
- accelerate decision-making processes through a less-centralized management;
- improve Pfaudler's ability to attract new talent at the local level.

The **MAVAG** product line provides technologies and services for **filtration, drying** and **agitation** for the pharmaceutical and biotech industry.

Our in-house fabrication capabilities comprehensive selection of equipments, systems and services enables us to provide higher levels of performance and efficient operation process solutions.



MAVAZWAG® Agitated Nutsche Filters and Filter Dryers (ANF and ANFD) are designed and manufactured with state-of-the-art technology from MAVAG. MAVAZWAG® ANF and ANFD are versatile units for deep bed, solid-liquid separation using a filter screen. MAVAZWAG® ANF and ANFD perform most effectively in Pharmaceutical and Chemical Industries where filtration and cake washing is required.

By adding a jacket on the vessel, heated blades on the agitator and operating under vacuum, the wet cake can be fully dried and discharge as a powder, all in a single unit.

All operations of an ANF and ANFDs are performed in an enclosed system, ensuring product quality, product consistency and operational safety.

Our ANF and ANFDs are also available in GMP/Sterile designs, which adhere to CIP/SIP requirements.

MAVAZWAG® ANF and ANFDs are available in Stainless Steel, Hastelloy and Special Alloys. For extremely corrosive applications, Pfaudler can offer ANF and ANFDs in Glass Lined construction. Pfaudler offers Pilot ANFD for on-site test work, enabling the user to gain valuable experience and gather reliable process data at the same time.

Our engineers work closely with you to assist in selecting the right ANF or ANFD and then optimizing it for your process conditions.

MAVAZWAG®

Key Features/Options

Vessel

- Base flange with C-clamps or quick-lock bayonet
- Jacket and seal welded insulation
- Designed according PED or ASME
- Wide range of WIP / CIP devices

Filter plate

- Clamp design for single layer filter media
- Filter media disc (boltless design) with multi- layer sintered filter media
- Unique filter plate design allows interchangeability
- Dead zone free construction

Agitator

- 2 or 3 arm special S-profile
- Heated design
- Bolt free connection for shaft bellow
- Wide range of shaft sealing options
- MAVAG "Clean Sweep" design for total heel discharge

Side discharge valve

- Hydraulically operated / fail safe
- Soft seal or metal/metal sealing

Peripheral systems

- Automation systems
- Temperature control units (TCU)
- Vacuum / gas recirculation systems
- Solvent recovery systems
- Powder handling / Pack-off systems



MAVAZWAG®

Design for high potent applications (HAPI)

- Double seal design with flush connection for filter base
- Integration of glove box / isolators on side discharge port for contained product discharge and heel removal
- Single or double chamber designs
- Square section side discharge port for superior product removal
- Save change for dust filter element

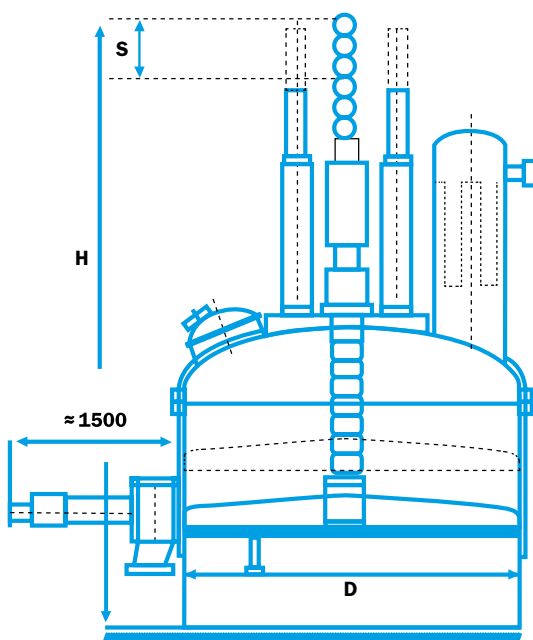

Filter surface m ²	Slurry volume ltr.	Max. cake volume ltr.	Diameter D mm	Height H mm	Stroke S mm
0,15	85	30	450	2500	200
0,25	160	70	600	2700	250
0,4	330	125	740	2900	300
0,5	380	150	800	2900	300
0,6	490	190	900	3000	300
0,8	600	230	1000	3200	300
1	1100	450	1200	3600	400
1,5	1500	600	1400	4100	400
2	2000	800	1600	4300	400
2,5	2500	1000	1800	4350	400
3	3000	1250	2000	4600	400
4	4000	1650	2300	4950	400
5	5200	2100	2600	5100	400
6	6700	3000	2800	5200	500
8	10000	4000	3200	5800	500
10	12000	5000	3600	6000	500
12	14000	6000	4000	6100	500



MAVALAB

Pre-Engineered mobile turn key pilot / small batch filter dryer

MAVALAB Filter Dryers are easy to operate, user friendly trial / small batch mobile units. Pre- engineered cost effective, manual solution providing all the process functionality of the traditional MAVAZWAG units.

Key features

- Hydraulic free compact design
- Shaft sealing with purged double mechanical seal

- Agitator drive with mechanical speed variator with pneumatic spindle design for agitator stroke
- Manually operated side discharge valve
- Control panel according ATEX or NEMA

Options

- Dust filter
- WIP / CIP devices
- Integration in isolator /glove box



Filtration area		Slurry Volume		Cake Volume		Vessel diameter		Overall dimensions LxWxH	
M ²	Ft ²	Liters	Gallons	Liters	Gallons	MM	In.	MM	In.
0.03	0.3	13	3.4	4	1	195	7.7	1450x750x1900	36.8x29.5x74.8
0.06	0.6	25	6.6	9	2.4	273	10.8	1500x800x1800	59.05x31.5x70.9
0.1	1.1	43	11.4	14	3.7	350	13.8	1600x900x1850	63x35.4x72.8
0.15	1.6	85	22.5	32	8.5	450	17.7	1920x1100x2410	75.6x43.3x94.9
0.2	2.2	125	33.0	46	12.2	540	21.3	2020x1200x2410	79.5x47.2x94.9
0.25	2.7	155	41	57	15.1	600	23.6	2100x1250x2410	82.7x49.2x94.9
0.4	4.3	250	66	107	28.3	740	29.1	2400x1530x2760	94.5x60.2x108.7
0.5	5.4	300	79.2	126	33.3	800	31.5	2450x1600x2760	96.4x63x108.7

MAVAG single plate manual nutsche filters

Single plate nutsche filter for manual cake discharge

Key features / options:

- Available filtration surface area from 0.1 – 1.5 m²
- Manual or hydraulic base plate lowering
- Tilting or swivelling top cover
- Body flange with C-clamps or quick lock
- Cake retainer ring
- Mobile or stationary designs
- Special designs with tilting vessel or manual agitator
- Available in Stainless Steel, Hastelloy or other special Alloys, Glass Lined or Fluoropolymer Linings





FUNDA®

Centrifugal Disc Filters



The FUNDA® Centrifugal Disc Filter is a totally enclosed pressure filter with horizontally arranged, self-supporting filter screens for pre-coat or residue filtration of large quantities of diluted suspensions in an automated, closed system. Heel volume filtration to minimize product losses. Cake washing in cascade operation.

FUNDA® Centrifugal Disc Filter are available from 1m² up to 80 m² filtration area in two basic configurations, Type R for cake discharge or Type A for slurry discharge. For added versatility, Type R filters can be configured for both cake and slurry discharge. Filters can be supplied in Stainless Steel, Hastelloy and other special Alloys. Pilot units are available for on-site test work, enabling the user to gain valuable experience and gather reliable process data for scale-up.

MAVAG offers a complete range of off-the shelf options plus the engineering applications know-how to configure your filtration system to your specifications. With standard components proven effective many times over, it's a sure way to bring a new system on-line quickly and without problems.



FUNDA®

Key Features / Options

Vessel

- Legs or support lugs
- Jacket and seal welded insulation
- Designed according PED or ASME

Filter plate

- Dished filter plates with spacer rings and clamp ring
- Various types of filter media available including multi-layer sintered filter media

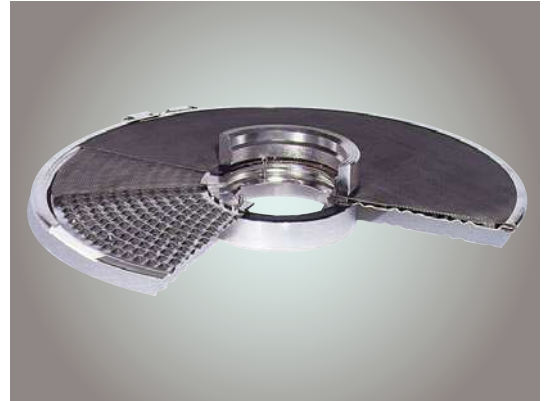

Filter drive

- Electric drive with gear reducer or hydraulic drive
- Wide range of shaft sealing options

Peripheral systems

- Automation systems
- Complete process skids
- Pack-off systems



MAVASPHERE®

Spherical Dryers



The Mavasphere®Spherical Dryer is a multi purpose dryer used in the drying of Active Pharmaceutical Ingredients (API's) and Fine Chemicals in compliance with cGMP and FDA guidelines. The Mavasphere®provides excellent drying performance over a wide range of filling capacities with a good turn down ratio.

Material of Construction

Stainless Steel, Hastelloy and Special Alloys.

Shaft Sealing Design

Gas lubricated double mechanical seal installed outside of the product zone.

Agitator

Hollow heated rotating 3-blade agitator with minimal clearance between agitator blade and vessel wall.

Bottom Discharge

Spherical disc valve for quick opening and discharge of dried product with no dead volume.

Standard Accessories

Lump Breaker, Dust Filter and Sampling System.

Optional Accessories

- Vessel flange with bayonet type quick closing design with hydraulic hinge for easy opening of lower vessel half allowing simple inspection and maintenance
- Automation Systems
- Temperature control units (TCU)
- Vacuum and solvent recovery units
- Powder handling / Pack-off systems

We offer a pilot dryer for on-site test work.

MAVASPHERE®

Spherical Dryers

Key features and advantages:

- Minimal clearance between the vessel wall and agitator for efficient and uniform drying
- Entire vessel covered by jacket for better heat transfer
- Wide range of filling capacities with a good turndown ratio
- Minimal product hold-up for easy cleaning and validation
- Eccentrically top mounted agitator for uniform mixing and gentle drying of product
- Discharge at lowest point for complete product discharge
- Compact system with lower footprint
- Chopper for very effective lump breaking and sticky products

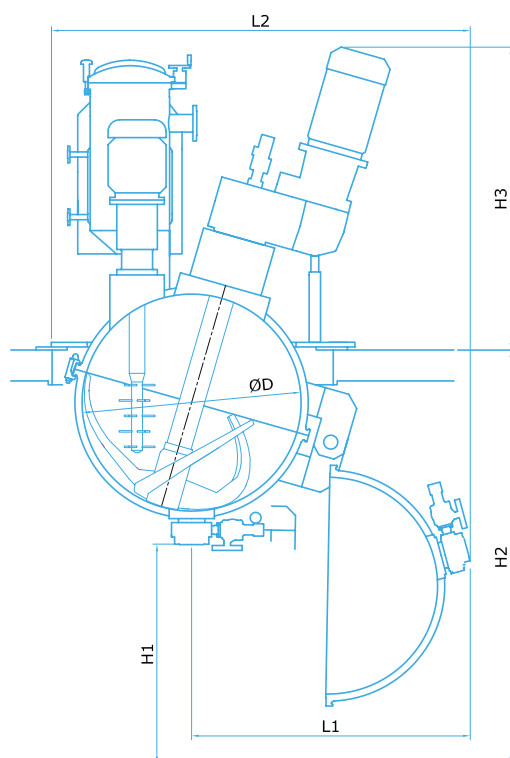

Technical data

Model	Working volume ltr.	Ø D mm	H2 & H3 mm	L2 mm	H1 mm	Drive Power kW
Type 100	100	700	3000	2200	900	11
Type 200	200	800	3200	2300	900	18.5
Type 400	400	1050	3500	2500	1000	22
Type 1000	1000	1400	4500	2800	1150	30
Type 1500	1500	1600	5100	3000	1300	30
Type 2000	2000	1700	5500	3500	1400	37
Type 4000	4000	2100	6200	4200	1550	45
Type 6000	6000	2400	6500	4650	1700	55

DRYING
Vacuum
Drying

MAVAPAD

Vacuum Paddle Dryers



The Mavapad® Vacuum Paddle Dryer is a versatile energy efficient system used for the drying of Active Pharmaceutical Ingredients (API's) in compliance with cGMP and FDA guidelines. The Mavapad® can be designed for use in sterile/clean room areas by providing a stainless steel partition wall that separates the drive unit from the process area.

Our engineers can assist in sizing and optimizing the Mavapad® to meet your process requirements.

Material of Construction

Stainless Steel, Hastelloy and Special Alloys.

Shaft Sealing Design

Double wet mechanical seal or dry mechanical seal to eliminate product contamination.

Agitator

Hollow rotating agitator with improved paddle design for better heat transfer.

Bottom Discharge

Twist Close Valve/Segmented Ball Valve for quick opening and discharge of dried product with no dead volume.

Standard Accessories

Dust Filter.

Optional Accessories

Lump breaker, Sampling system, Condenser, Receiver and Vacuum Pump.



**HIGH
QUALITY
COMPONENTS**

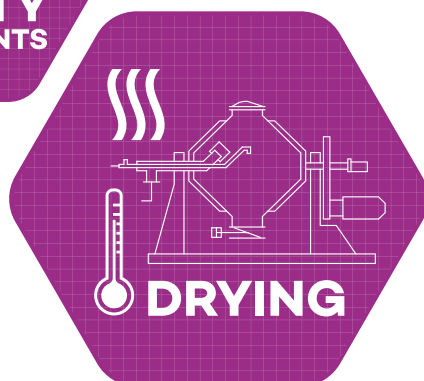

DRYING

MAVAPAD

Vacuum Paddle Dryers

Key features and advantages:

- Large heat transfer area (vessel body and agitator) for faster drying
- Flat ends instead of dished ends for lower heel volumes and better emptying characteristics
- Full door opening for easy cleaning and validation
- Lower operating and maintenance cost compared to other dryers

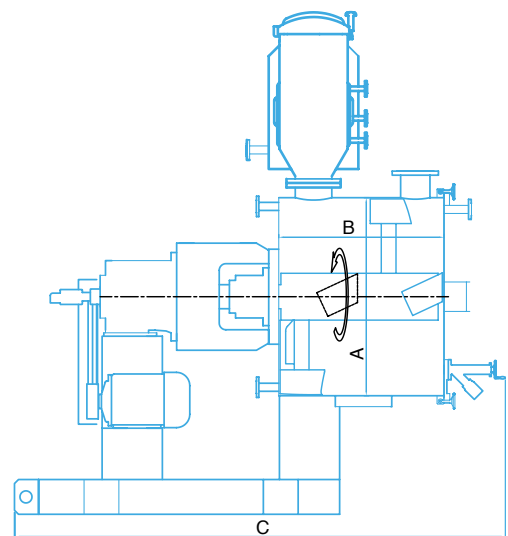
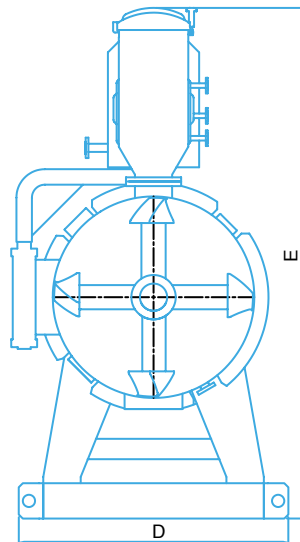

Technical data

Model	Total volume ltrs.	Usable volume Kg	Diameter A mm	Shell Length B mm	Total Length C mm	Base Width D mm	Overall Height E mm
RXPD 100	140	105	525	650	1900	700	2000
RXPD 200	210	140	650	625	2200	900	2150
RXPD 300	350	250	750	800	2700	1050	2500
RXPD 500	510	360	850	900	2900	1200	2700
RXPD 800	820	570	1050	950	3400	1500	3500
RXPD 1000	1130	800	1175	1050	3600	1650	4300
RXPD 1500	1600	1120	1300	1200	3900	1800	4900
RXPD 2000	2120	1480	1500	1200	4300	2200	5500
RXPD 2500	2640	1850	1550	1400	4500	2350	6000
RXPD 3000	3200	2550	1675	1450	4900	2600	6400
RXPD 3500	3850	2700	1750	1600	5200	2750	6800
RXPD 4000	4300	3000	1850	1600	5300	2900	7400

Chemical designs available up to 15000 L

DRYING
Vacuum
Drying

MAVADRY

Universal Vacuum Paddle Dryers

High performance paddle dryer with special heated airfoil blade with integrated high-speed chopper in one arm. High torque hydraulic drive for flexible degree of filling and wide range of physical product characteristics.

Available in Stainless Steel, Hastelloy and Special Alloys in sizes 100 L to 4000 L.

Key features and advantages

- Minimal clearance between vessel wall and agitator for efficient and uniform drying
- Entire vessel covered by jacket for better heat transfer
- Wide range of filling capacities with good turndown ratio
- Wet or dry chopping in combination with stator for milling
- Hinged front door for easy access or inspection



A worker in a blue cleanroom suit, including a hairnet and face mask, is operating a control panel in a large industrial facility. The facility is filled with complex machinery, including large stainless steel tanks and pipes, typical of a pharmaceutical or chemical production plant. The lighting is bright and even, highlighting the clean and organized environment.

MAVAG

**is the main specialist for
filtration, drying and agitation.**

**Chemical and
Pharma Industry**

**Paint, Dye and
Agro Chemicals**

**Production of
Fine Chemicals**

**Food, Biotech and
Cosmetics Industry**

www.mavag.com

Pf
Pfaudler
Defining the standard

MAVAG is part of the Pfaudler Group.

CH: sales-mavag@pfaudler.com
www.mavag.com

1 May - 1E
02/2018